

DISC FORAGE CROPPER

S. Uminsky, L. Knaub, A. Moskalyuk, S. Zhitkov
Odesa State Agrarian University

In the theoretical substantiation of the grinding process of crushed corn stalks in the working area of the disc grinder, the random stacking of particles of irregular shape in the average cross-section was considered. The principle of operation of the shredder consists in breaking pieces of the product in the working zone formed by the surfaces of the moving and stationary discs. At the same time, the intensity of grinding increases as the material moves from top to bottom in the decreasing working gap.

The design of the disc feed shredder is substantiated, which will ensure a reduction in the metal content of the structure, and will allow the production of feed mixtures of a given granulometric composition.

Keywords: grinding, flowability, energy intensity, drum, toothed disc.

STATEMENT OF THE PROBLEM, ANALYSIS OF RESEARCH AND PUBLICATIONS

The process of grinding rods is accompanied by significant energy consumption, and the degree of processing of the material is insignificant. So, for example, the use of a two-roll crusher, with a productivity within 2 t/h, allows you to obtain the size of forged rods up to 40 mm, and the specific energy consumption for the process reaches 5 kW h/t with a specific metal capacity of the structure of 505 kW h/t.

The given data indicate the irrationality of using the existing equipment for grinding corn stalks, but at the same time, taking into account their considerable length, one should recognize the expediency of the technological operation of preliminary processing of the stalks before their subsequent grinding with negligible total energy consumption, because it allows to increase the productivity of the machine, which implements the second stage of the process, and to improve the conditions for crushing the rods to a grain of the required granulometric composition.

Taking into account the given data, and the analysis of the composition of technological lines, the principle of operation and the design of machines used for grinding corn cobs and grain-stalk mixture, which are widely used in fodder production, it was established that the most common machines that implement this technological operation are hammer crushers of different designs, referring to impact machines in which material is crushed by free or compressed impact and abrasion.

The main working bodies of hammer crushers, which carry out the process of material destruction, are a rotor with hinged hammers of various configurations and a sieve with a deck [1]. There are well-known designs of hammer crushers for crushing corn cobs of the DKM type [2], with two-stage grinding with a device in the form of front and rear hammer drums, under each of which a tray with counter-cutting elements is installed. There are well-known designs of stationary machines [3] for grinding cobs and wet corn grain, in which the product is destroyed due to impact cutting.

Known designs of a chopper-mixer [3] with six packs of knives and counterslices, in the lower part of the rotor of such a machine there is a device for unloading the crushed product. Disadvantages of such structures include the instability of the grinding process with significant energy-intensive grinding. The main disadvantage of the considered machine designs is the low degree of grinding and the high energy consumption of the grinding process.

Table 1. Comparative technical characteristics of crushers for grinding high humidity corn cobs.

Indexes	Units of measurement	IRT 165	DM-8	IRM-50	IRM-15	DKM-5	DIS-1M
productivity	t/y	20	8	15	123	82	12
Moisture of cobs	%	43,2	43,5	46,2	30,2	33,9	45,8
Rotor speed	min-1	2000	2950	1610	-	3000	2260
Installed capacity	kW	110	30	90	55	30	22
Specific energy consumption	kW h/t	5,5	2,7	6,0	4,5	3,7	1,8
Mass of shredders	t	5,1	0,385	2,57	2,2	1,03	0,8
Specific metal capacity	kW h/t	255	89	171	179	125	67
Until 2		42,7	39,3	35,6	48,0	41,5	7,6
2...3		21,9	18,3	14,3	19,2	19,8	3,6
3...4		10,4	19,0	10,6	15,8	16,6	4,7
More than 4		15,0	21,9	39,5	17,0	22,10	87,1
Grinding module, mm		2,3	2,5	3,2	2,35	2,76	6,95

PURPOSE OF THE RESEARCH: to justify the design of the disc food grinder, which will allow to obtain a mixture of the given granulometric composition, to achieve a reduction in the metal content of the design and the energy consumption of the grinding process.

MATERIALS AND RESEARCH METHODS

The position of the working elements of the disk shredder corresponded to the "edge against the edge" scheme, in which the working area of the machine, due to the inclined location of the cutting grooves at an angle α , to the cone forming, was "scissors" that ensure product grinding using shear deformation. With the selected design and the geometry of the working organs of the disc grinder, it is assumed that the material particles are cut from each side by the amount of the tooth height. to zero along with normal ones.

Constructions [4] are also used, which contain a body to which the loading funnel and the unloading tray are attached, the working body is made in the form of a cross with knives, on the frame of which removable sieves pressed by cutting knives, a pressure disc, and a drive are installed. Unloading trays are attached to the lower part of the working body.

The cutting element is mounted on a disk and spirally installed saws (vertical and horizontal), the pitch of the teeth of which increases from the center. Due to the repeated cycle of deformation, which leads to regrinding of the material, as a result of which it is significantly heated during the operation of the shredder, the high energy intensity has not found application in agricultural production.

RESEARCH RESULTS

The set goal is solved by the fact that, in the disc grinder, which contains a receiving nozzle, a valve, a housing, an auger, a movable toothed disc, a fixed toothed disc, an outlet nozzle, inclined triangular grooves of the same width are made along the concentric circles of the toothed discs, which intersect at a certain angle so that the cutting edges on the moving and stationary toothed disks are directed towards each other. Fig. 1 shows the scheme of the disk feed chopper, which consists of the intake pipe 1, valve 2, housing 3, bearing units 4,5, hollow shaft 6, auger 7, movable toothed disk 8; compensating spring 9, nuts 10, 16, fixed toothed disk 11; screw mechanism 12, rod 13, finger 14, plate 15, outlet nozzle 17, impeller 18, electric motor 19, V-belt transmission 20.

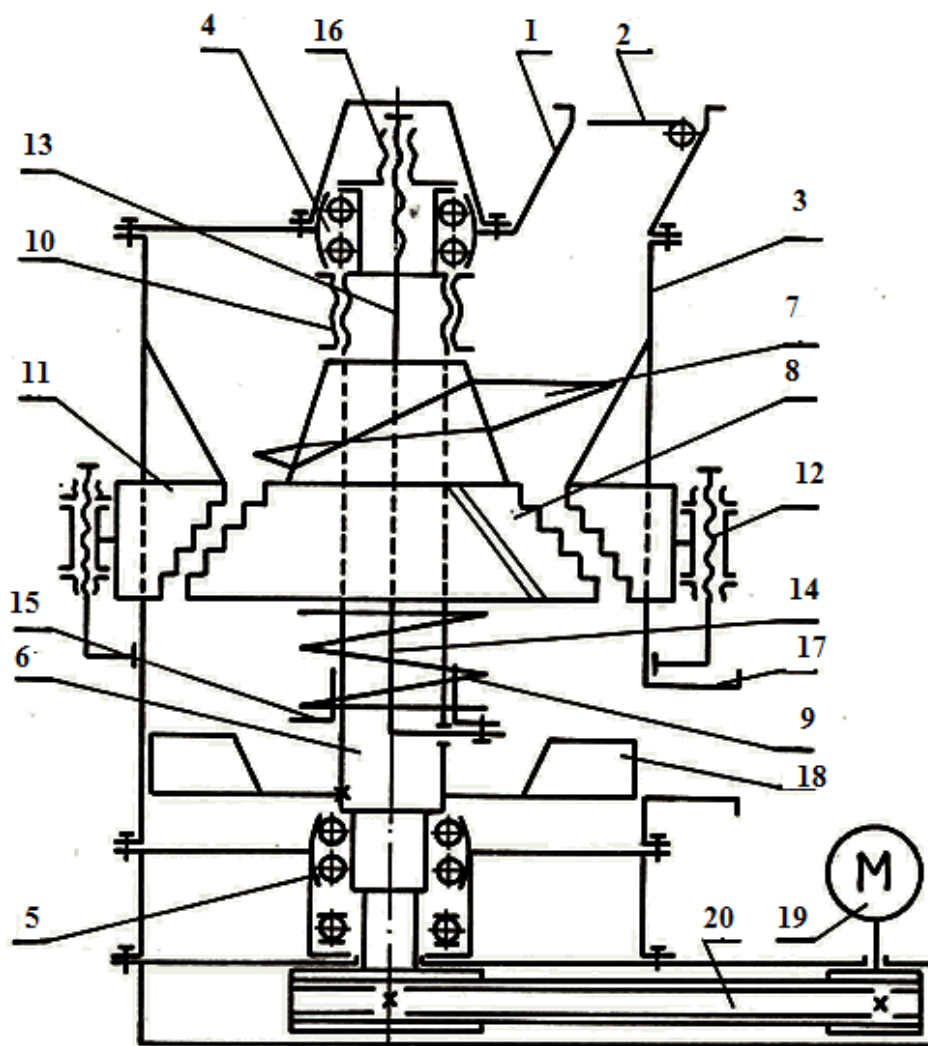

Fig. 1. Scheme of a disc feed chopper.

The disk chopper is designed for the production of crushed grain rods of a given granulometric composition, and consists of a receiving nozzle 1 with a valve 2 for regulating the supply of the product and a housing 3, inside which a rotating hollow shaft 6 is installed in the bearing assemblies 4 and 5. An auger 7 is fixed on the shaft, which feeds, and the rotating movable toothed disk 8, which has the ability to move, overcoming the resistance of the compensating spring 9 when a foreign solid body is hit in the working area of the machine. To prevent upward movement of the auger and disk, fixation with a nut 10 is provided.

The working zone, formed by the internal movable disk 8 and the external conical gear fixed disk 11, due to their conicity, had a larger input annular gap than the output one. The sizes of the clearances were changed by moving the fixed disc along the height of the body with screw mechanisms 12. The adjustment of the compression force of the spring 9 was carried out by a rod 13, which has a thread at the upper end, and a finger 14 at the lower end, rigidly connected to the plate 15, on which the spring rests. When the nut 16 rotates, the spring is compressed and thereby increases the force that the disk must overcome during movement. The crushed product is removed from the machine through the nozzle 17 with the help of the impeller 18, rigidly fixed on the shaft 6. The chopper was driven by a 4.5 kW electric motor with a speed of 1000 rpm through a V-belt transmission 20. The chopper design uses working bodies with a complex profile geometry of their surface, which grinds the product due to compressive, tensile and shear forces, which ensured obtaining grains of the correct shape and given granulometric composition.

The surfaces of the discs have inclined grooves of a triangular shape with a width of 10...14 mm and a depth of 4...6 mm, while the grooves of the movable and stationary gear disc intersect at a certain angle. Unlike existing structures, the width and depth of the grooves are chosen to be 12 mm and 5 mm, respectively, based on the results of experiments.

CONCLUSIONS

Considering that one of the determining, geometrical parameters of the disks, which significantly affect the conditions of product movement in the working area of the shredder and the efficiency of the process, is the angle of inclination of the cutting edges on the disks, three standard sizes of disks are used with an angle value of 20, 45° and 70°, respectively. At the same time, the grooves are made in such a way that the cutting edges on the movable and stationary toothed discs are directed towards each other. In a grounded shredder, flow grooves of the same width are made along the concentric circles of the discs, and their height is chosen in the ratio 1:2 so that the protrusions on the moving toothed disc enter the depressions formed by the grooves of the stationary disc, as a result of which, when changing the working clearance along the height of the disks decreases, the size of the passage cross-section of the grooves.

REFERENCES

1. Zubets M.V., Tyvonchuk S.O. (2014). Development of innovative processes in agro-industrial production. K.: Agrarian science, 189 p.
2. Dudarev I., Uminsky S., Moskalyuk A., Zhitkov S. (2023). EVALUATION OF CAROTINE CONTENT IN COMBINED FEEDS Agrarian Bulletin of the Black Sea Littoral. Issue 109. ISSN 2707-1154/ ISSN 2707-1162. P.65-68. DOI 10.37000/abbsl.2023.109.10
3. Dmytriv V.T. (2002). Machine use in animal husbandry. Lviv: LDAU, 202 p.
4. Dudarev I.I., Uminskyi S.M., Moskalyuk I.V. (2022). Justification of the operational parameters of the disc feed chopper. "TES" Publishing House and Printing House, ISBN 978-617-77711-99-4, 140 p.

ДИСКОВИЙ ПОДРІБНЮВАЧ КОРМІВ

С. Уминський, Л. Кнауб, А. Москалюк, С. Житков
Одеський державний аграрний університет

При теоретичному обґрунтуванні процесу здрібнювання дріблених стрижнів кукурудзи в робочій зоні дискового подрібнювача розглянуто випадкове укладання часток нерегулярної форми в середньому перетині. Принцип дії подрібнювача полягає в розламуванні шматків продукту в робочій зоні, утвореній, поверхнями рухливого й нерухливого дисків. При цьому інтенсивність здрібнювання збільшується в міру просування матеріалу зверху вниз у зменшуваному робочому зазорі.

Обґрунтовано конструкцію дискового подрібнювача кормів, яка забезпечить зниження металоемності конструкції, дозволить виробляти кормові суміші заданого гранулометричного складу.

Ключові слова: здрібнювання, сипкість, енергоємність, барабан, зубчастий диск.